

Design and Implementation of a Low-Cost Fully Automated Solar-Powered Mower Vehicle

R. Harshvardhan¹, A. S. S. Murugan², D. Obulesu² and N. Karuppiah³

^{1,2,3}CVR College of Engineering, Mangalpalli, RR District, Telangana

⁴Vardhaman College of Engineering, Kacharam, Hyderabad, Telangana

Email: 83.harsha@gmail.com, assm17174@gmail.com, dakkaobulesh@gmail.com,
natarajankaruppiah@vardhaman.org

Abstract

This research concentrates on the hardware design of a photovoltaic grass cutter, which is used to cut various grasses for various uses. A solar panel with a battery system will provide the supply for the DC motor with cutting blades assembly. The paper focuses on using digital technology where a robot vehicle can cut the grass on a lawn, small farm, etc. The system will be totally automated. Obstacles in the path are detected with the help of an ultrasonic sensor. This structure uses four motors, two of which are used for grass cutting (high-speed DC motors) purposes, and the other two are utilized for vehicle movement. For power saving and automation purposes, the system is developed with a solar panel and battery.

Keywords. Solar pv panel, Mower vehicle, Ultrasonic sensor, Motor, Battery.

1. INTRODUCTION

In general, the wide grasslands in various places of institutions, green spaces, and nature reserves are maintained by garden labour with his hand and scissors. However, it is not uniform, and completing the assignment within the time limit is not a simple task and requires a significant amount of human work. The only viable answer is automation, which has decreased both time and labour requirements [1-2]. Today's globe is experiencing a shortage of electricity and all other quasi energy sources, and these resources could eventually run out [3]. Therefore, we focused on environmentally friendly renewable energy sources like the sun's electricity.

The photovoltaic-powered mowing robot is a completely automated machine that uses little energy and needs few workers to cut the grass [4-6]. It also identifies obstructions in the way and adjusts the movement direction accordingly. There is no need for human interaction.

If something gets in the way of the grass cutter, the proximity sensor detects it and sends a signal to the microcontroller to adjust the direction [7]. The sensors function as an automated machine's eyes. A blade is attached to the automated equipment that cuts the grass swiftly and at a high RPM [8].

2. WORKING OF SOLAR MOWER VEHICLE

It is equipped with photovoltaic panels that are set up so that it is simple to take in the sun's intense solar radiation. Solar photovoltaic structures instantly transform light energy from the sun into electricity. Using a solar charger, this electrical energy is now stored in the battery. When the battery storage system is charging, the solar controller's sole role is to enhance the current generated by the solar photovoltaic system. Additionally, it unplugs the solar photovoltaic system from the battery energy storage device when it is completely packed and hooks up again whenever the pack is running short on electricity. Through connecting wires, the motor is connected to the battery. A 555 timer is used as part of the control circuit. A photo-electric proximity sensor is also included for obstacle avoidance. The 555 timer's pin-2 is triggered when an impediment is identified, causing the required delay. As a result, the relay activates and cuts the supply to the right-hand motor, causing the car to spin and continue moving. The blades are powered by a high-speed motor that is connected directly to the battery.

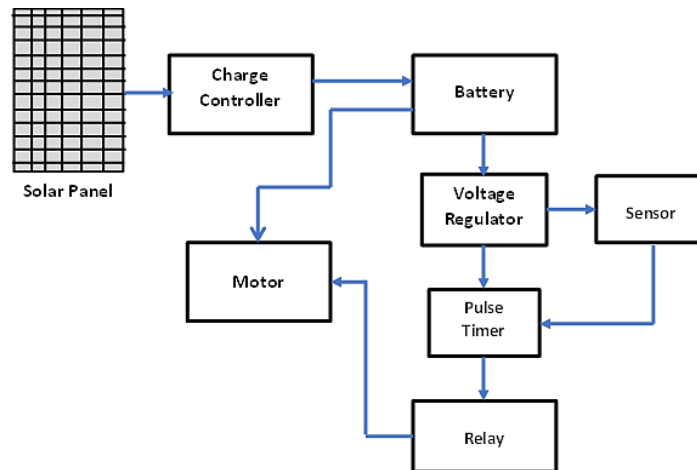

Figure 1. Schematic representation of the suggested system

3. **HARDWARE PARTS**

3.1. *Solar PV Panel*

Sun photovoltaic cells are energy-converting devices that convert solar light into electricity in a solar panel [9-11]. A PV system with a 5-watt power output and voltages of 21.6 volts at no load and 17 volts at full load. A charge controller, which regulates the voltage and current of the battery's charging, links the photovoltaic panels to the battery.

Solar Panel Specifications

- Rated Power (P_{max}) : 5W
- Electric potential in open circuit (E_{oc}) : 21.6V
- Current during short circuit condition (I_{sc}) : 0.33A
- Specified Potential (V_{mp}) : 17.0V
- Specified Current (I_{mp}) : 0.30A
- Power Tolerance : $\pm 3\%$
- Specifications are at STC : 1000W/m²
- Insolation AM 1.5, Cell Temp 25°C

3.2. *Charge Controllers for Solar Panel*

The power charge manager, also referred to as a battery charger, is situated somewhere in between the battery bank, the equipment, and the applications [12]. Regulators used in solar applications should be connected in series to minimize overcharge and over discharge by monitoring the voltage of the battery. Gadgets are linked and disconnected using switches, which can be solid state or electromagnetic types of relays.

It is never a good idea to connect solar chargers in series. The switch opens the charging circuit when the battery's voltage exceeds the high voltage disconnect (HVD) or cut-off break point, preserving the battery against overheating. By cutting the load, the low voltage disconnect (LVD) prevents the battery from being overcharged. The PV panels can be automatically unplugged by sophisticated controllers to prevent the battery from being discharged at night. Additionally, to increase the storage battery's lifespan, they can periodically discharge it by employing a process known as the pulse width modulation (PWM) technique. The PV panel charger features three LED displays. As soon as the battery packs receive a solar charge, the first LED flashes. The very next light turns on when the battery

Proceedings of First International Conference on Smart Systems and Green Energy Technologies (ICSGET 2022)

performance of the device is low. The Final LED bulb turns on when the batteries have been charged completely and a further load has been applied to them.

Solar Panel Specifications

- Specified power capacity (Pmax) : 5W
- Potential across the circuit during open circuit open circuit (Voc) : 21.6V
- Current in the line during short circuit condition (Isc) : 0.33A
- Specified potential (Vmp) : 17.0V

3.3. 555 IC

A semiconductor called the 555 Integrated circuit (IC) can be used to make oscillators, signal makers, and repeaters. 25 transistors, 2 diodes, and 15 resistors are contained inside this basic 555 semiconductor IC chip, which has an 8-pin dual-in-line package (DIP-8).

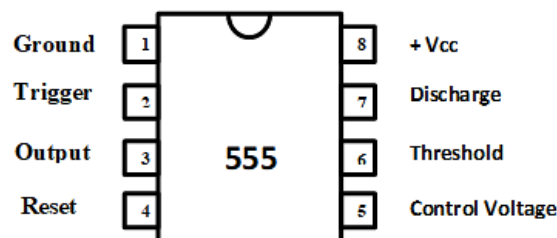

Figure 2. Pin diagram of 555 Timer

The voltage divider circuit, which typically consists of three 5k resistors linked in series, provides trigger values that really are one-third of VCC ($VCC/3$) as well as two-thirds ($2/3$) of the threshold voltage. Whenever necessary, the control voltage terminal (Pin 5) can be used to change the trigger and threshold settings. The requirements are adjusted by varying the control voltage at Pin 5, which also alters the trigger level and threshold voltage.

3.4. Photo-electric Proximity Sensor

It is an infrared sensor with an NPN output and a detection range of up to 30 cm. It is being used to detect obstacles in autonomous machines and mobile robots. It is, indeed, a scan that requires no interaction. Modulated IR signal implementations protect the sensor from interference induced by regular light from a light bulb or sunlight.

The sensor distance can be manually changed. It includes all sensors that detect objects without physically contacting them, as contrast to sensors, such threshold breakers, which sense the environment through manually touching them. The

Proceedings of First International Conference on Smart Systems and Green Energy Technologies (ICSGET 2022)

information regarding an element's motion or existence is transformed into an electrical signal using motion detectors.

Three different kinds of detection systems are employed to perform this transformation: one which employs magnetic fields to create eddy currents in metallic sensing objects; one that detects modifications in electrical characteristics as they get near to the detecting object; and the last one, which uses electromagnets and switching devices.

3.5. Voltage Regulators

Voltage regulators are meant to keep voltages consistent in the event of a power outage. The voltage regulator LM7805 is utilized. It belongs to the 78xx family of constant voltage regulator integrated circuits. It is impossible to deliver a constant output voltage since voltages in networks might oscillate. The terminal voltage is maintained steady by the voltage regulator IC. The LM7805 is a regulated power supply with a voltage of +5V. Capacitors are placed at the input and output levels based on the operating voltage.

The input voltage pin (PIN 1) has an operating voltage range of 5 to 16 volts. PIN 2 stands for the Ground PIN, and PIN 3 is the controlled output PIN with a 5 V voltage (in the voltage range of 4.8 V to 5.2 V).

3.6. Relays

The majority of supervisory apparatus or systems utilizes relays both as changeover and principal security features. Any relay can release or close associates or networks by reacting to one or more electrical qualities like voltage or current. A relay functions as a switching device by isolating or changing the state of an electrical circuits from one state to another.

Requirements for a relay

- Typical changeover currents of 7 A and 10 A
- Peak controlling voltage: 28 volts DC or 250 volts AC
- Dielectric strength V_{rms} : 750 V AC between open contacts and 1000 V AC seen between coil and the junctions
- the ambient 1000 V AC is present between the contacts; -40 to +85 °C is the ambient temperature is -40 to +85 °C and 10/8 ms is the operation/release time; and 10A 125V and 7A 250V are the contact capacities.

3.7. *Battery*

Two power supplies are required to control the grass cutter. One to power the control circuit and the other to power the motors. The battery's voltage rating and capacity must be chosen correctly. For ease of maintenance, both power supplies must be rechargeable. Due to the intended use of the batteries, sealed lead batteries with recharging capabilities were chosen. The motors are powered by a 12V battery. Because one battery is insufficient to drive the motors, it is more practical to use two parallel batteries.

Solar energy storage requires a battery with the following specific combination of qualities to be economically viable:

- Cheap price and high durability
- Relatively high efficiency and dependability

Battery packs details

- Model: AT12-1.3 (12 V 1.3 AH/20 Hr)
- Cycle use is 14.4–15.0 volts, while standby use is 13.5–13.8 volts.
- Preliminary current: under 0.39 A

3.8. *Motor*

The vehicle is primarily powered by three DC motors. Two of them are utilized for motion, while the other is used to cut the grass. As a result, the vehicle will be able to chop grass while running around the field. A DC motor with a rating of 300 W and 12 V is used in this experiment.

4. **HARDWARE IMPLEMENTATION**

4.1. *Hardware Implementation*



Figure 3. Control Circuit

Proceedings of First International Conference on Smart Systems and Green Energy Technologies (ICSGET 2022)

The hardware is made up of two circuits. The first circuit is the timer circuit, which gives the necessary timing delay. The delay time is determined by the RC time constant. As a result, the capacitor and resistor values are chosen suitably. For the time delay in this circuit, 10K resistance and 1000 μ F capacitance are selected. Another circuit is the supply circuit, which provides power to allow the batteries to be recharged via the solar panel.

A photoelectric proximity sensor is used for obstacle detection. Through the battery, it receives 12V from the voltage regulator. It is made up of three wires, two of which are connected to the supply, and the other two to the regulator. The third wire is connected to the 555 timer's pin-2. When an impediment is recognized, pin 2 is lifted high, causing the relay to activate.



Figure 4 (a). Wheels for the robotic vehicle



Figure (b). Blade assembly

For forward motion, the entire assembly is mounted on a robotic vehicle with wheels. The motor shaft is connected to the wheels, which are powered by the batteries. A blade is coupled to a high-speed motor that is used to cut the grass. As soon as the motor is switched on, the blades begin moving rapidly, cutting the lawn.

4.2. Torque Calculations and Hardware Output

$$\text{Power } P = 2\pi NT/60$$

Where N = Motor speed in RPM and T = Torque of the motor (N-m)

(i) Torque measurement in the absence of a load

Power (P) = 12 volts \times 25.2 Amps = 302.4 Watts, find torque

$$302.4 = (2 \times \pi \times 800 \times T)/60, \quad \mathbf{T = 3.61 \text{ N-m}}$$

(ii) Torque measurement in loaded conditions

$$P = V \times I = 12 \times 28 = 336 \text{ W},$$

$$\text{find torque, } 336 = (2 \times \pi \times 620 \times T)/60, \quad \mathbf{T = 5.17 \text{ N-m}}$$

In this work, three motors are used to power the vehicle. Two motors are employed to move things around, while the third one is used to mow the lawn. As a result, when running around the field, the vehicle will be able to chop grass. The

Proceedings of First International Conference on Smart Systems and Green Energy Technologies (ICSGET 2022)

automobile makes the turn when it detects an impediment using a proximity sensor. The solar panel charges the vehicle, which is then stored in a battery. The task was done satisfactorily.

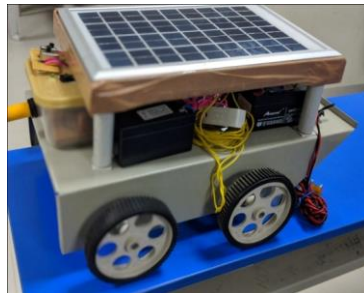

Figure 5. Prototype of fully automated solar grass cutter

5. CONCLUSION

The major goal of this work is to create a PV system-based automatic robotic lawn mower system that will assist in mowing the lawn in various designs while requiring less human labour. The system's benefits include the inexpensive cost of the components used. Because there is no need for fuel, this solar-powered lawn cutter will meet the demands of environmental protection and cheap operating costs. For use by homes and companies with lawns that cannot be mowed with tractor-driven mowers, a PV system based automatic mower vehicles has indeed been developed. The capacity of the machine is sufficient for its intended use. The machine has been shown to be a viable alternative to fuel-powered lawn mowers. A succinct synopsis of the results and a precise description of the system represents advanced contribution in that field.

REFERENCES

- [1] J. Billingsley, 'Agricultural Robotics', IEEE Robotics Automation magazine, 2009.
- [2] T. Liu, B. Zhang, J. Jixing, 'Electromagnetic navigation system design of the green house spraying robot', Int. Conf. on Mechanic Automation and Control Engg., pp. 2140 – 2144, 2011.
- [3] G. D. Rai, 'Non-Conventional Energy Sources', Khanna Publishers, 1988.
- [4] D. Athina, K. Kumar, B. Kalyani, K. Vittal, 'Solar Grass Cutter Using Embedded Platform an Experimental Validation', IOP Conf. Series: Materials Science and Engg., pp.1057, 2021.
- [5] A.P. Pralhad, B.S. Bhagwan, K. S. Subhash, P. N. Vijay, R. U. Kale, 'Solar powered automatic grass cutter and pesticide spreading robot', Int. Res. J. Eng. and Tech., Vol. 4, Issue 5, pp 3372-3375, 2017.

Proceedings of First International Conference on Smart Systems and
Green Energy Technologies (ICSGET 2022)

- [6] D. T. Yashit, A. Hariya, A. Kadachha, D. Dethaliya, 'Fully automated solar grass cutter', Int. Journal of Sci. Tech. & Eng., Vol. 3, Issue 9, pp. 104-106 2017.
- [7] A. K. Chaudhari, 'Solar based grass cutter' Int. Journal of Electrical and Electronics Eng., Vol. 9, Issue 1, pp. 134-1389, 2017.
- [8] S. Jain, A. Khalore, S. Patil, 'Self-efficient and sustainable solar powered robotic lawn mower', Int. Journal of Trend in Research and Development, Vol. 5, Issue 2, pp. 294-297, 2015.
- [9] B. R. Patil, S. S. Patil, 'Solar based grass cutting', In. Res. J. Eng. and Tech., Vol. 5, Issue 2, 2017.
- [10] S. Akshay, V. Dhananjaya, G. I. Menezes, P. R. A. Kumar, 'Design & Fabrication of Remote-Controlled Solar Lawn Mower', Int. Research Journal of Engineering and Technology, Vol. 6, Issue 4, pp. 4106- 4112, 2019.
- [11] B. P. Dilip, N. B. Pagar, V. S. Ugale, S. Wani, M. Sharmila, 'Design and Implementation of Automatic Solar Grass Cutter', In. J. Adv. Res. in Elect., Electro. and Instru. Eng., Vol. 6, Issue 4, pp. 2433-2437, 2017.
- [12] B. Ibrahim, V. S. Brahmaiah, and P. Sharma, 'Design of smart autonomous remote monitored solar powered lawnmower robot', Materials Today: Proceedings, pp. 1-7, 2020.