Experimental and Simulated Analysis of Tractor Seat during Tillage

Harbhinder Singh, Munish Mehta

*School of Mechanical Engineering, Lovely Professional University, Phagwara, India
harry2211@rediffmail.com, munishmehta1@rediffmail.com*

Abstract

Tractors work in fields and operators are mostly under the influence of negative vibrations as tractors are not provided with any type of suspension systems. These vibrations are harmful for the health of driver as drivers has to work for long hours. The present study is focused to analyse the seat of tractor experimentally by collecting the real time data from tractor seat while working in fields with implements during tillage process. Tri-axial accelerometer was used to collect the actual data from seat base and was stored in data collection unit. Based on the real-time data a dynamic model of tractor along with seat was developed in MATLAB-Simulink for further analysis of vibrations. Measurement of vibrations is the basis for developing a good tractor seat with reduced vibrations. Although, there still remained many problems to be solved but this study will provide a good base to work in this direction.

Keywords -Tractor, Implements, Vibration, Modelling and Simulation.

1. INTRODUCTION

Vibrations in the range of 12 Hz affect all organs of operator, whereas vibrations above 12 Hz have a local effect on organs. Low frequency (less than 6 Hz) movement, such as movements of tires over an irregular road, can cause body resonance [1]. Biodynamic research has shown that prolonged exposure to vibrations increases the risk on health [2].

Vibration characteristics which mostly influence human response are the direction, the point of contact with the body, frequency, magnitude, duration etc [3, 4, and 5]. Resonance occurs when the excitation frequency matches one of the natural frequency of the system [6]. This results in large oscillations, which are harmful/undesirable. When a system is disturbed and can vibrate by itself, the frequency at which it vibrates without damping and without external force is known as its natural frequency [7, 8]. If the damping is present, then it is; known as damped natural frequency of the system. Most seats exhibit resonance at low frequencies, which results in higher magnitude of vertical vibrations occurring on the seat [10, 11].

2. MATERIALS AND METHODS

The real time data was collected from the tractor seat. The experiment was conducted for two different implements. First time data was taken from tractor seat when the tractor was moving with plough and second time disc harrow (Figure 1) was used as implement for tillage process.



Figure 1. Tractor with Chisel Plough and Disc Harrow

During both cases vibrations were measured with tri-axial piezoelectric accelerometer (Figure 2). Vibrations measuring accelerometer was fitted on the seat base of test tractor to measure vibrations on seat of tractor. The frequency sensitivity range of an accelerometer was 2-8000 Hz. Every time, acceleration levels were recorded simultaneously in three perpendicular directions, X longitudinal (pitching), Y lateral (rolling), and Z vertical (bouncing/heave) on the base of the tractor seat.



Figure 2. Location of accelerometer on the base of tractor seat.

A setup was made for the measuring vibration in X, Y and Z direction (Figure 3). The vibration measuring accelerometer was capable to quantify the vibration of the X axis, Y axis and Z axis at 10 Hz frequency.



Figure 3. Tri-axial Sensor and Data Acquisition unit setup used for the measurement of vibrations

The tractor was made two runs at two constant speed during both cases and the real time data was recorded separately for each case along horizontal, transverse and vertical directions.

3. DATA ANALYSIS

Accelerations measured are shown in Figure 4 in horizontal (x), transverse (y) and vertical (z) direction. The speed of tractor was kept constant at 2.30 Km/hr. As the Figure shows when tractor was made to work with tillage implements (chisel plough) the measured RMS values of acceleration was highest in transverse (y) direction and lowest in horizontal (x) direction and the vertical (z) direction values lies in between that of lateral (y) direction and longitudinal (x) direction.

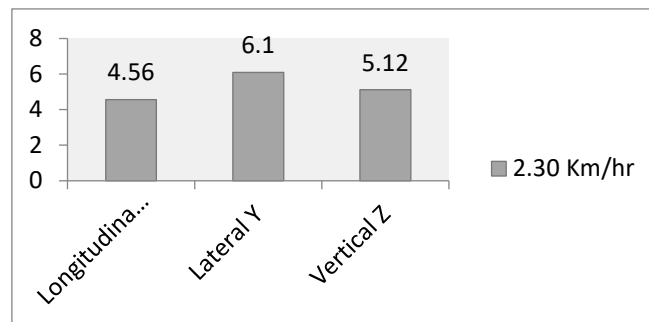

Figure 4. RMS acceleration in all three directions at tractor's seat with implements

4. IMPLEMENTATION- SIMULATED MODEL OF TRACTOR

In present work simulation of Full tractor vibration model with hitched implement was created. Moment of inertia and mass of tractor with implements was the key factor in representing the tractor-implement structure. The dynamic model of tractor and implement is shown in Figure 5. Due to surface roughness front tires and rear tires of tractor are subjected to displacement excitations $q_{fz}(t)$ and $q_{rz}(t)$ respectively. Because of the difference in amplitudes of $q_{fz}(t)$ and $q_{rz}(t)$ a displacement with respect to centre of mass comes into picture. Due to this displacement with respect to mass centre roll, yaw and pitch movements of tractor came into the picture.

The ground excitation between front axle and rear axle of the tractor-implement system at any instant t with a time lag between $q_{fz}(t)$ and $q_{rz}(t)$ can be expressed as

$$q_{fzi}(t) = q_{rzi}(t + \tau) \quad (1)$$

Where $q_{fzi}(t)$ and $q_{rzi}(t)$ are displacement excitations, τ is time lag and can be calculated as

$$\tau = \frac{l_{bf} + l_{br}}{v} \quad (2)$$

Where l_{bf} is distance of mass centre between chassis and front axle, l_{br} is the distance of mass centre between chassis and rear axle. Velocity of tractor-implement system is represented by v .

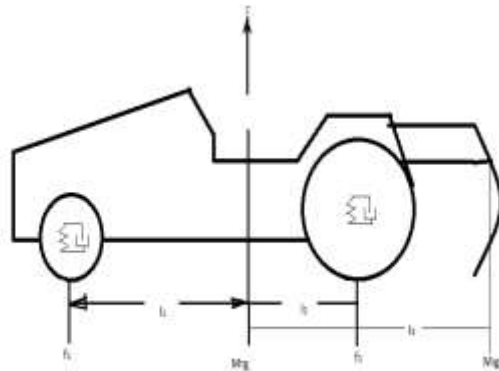

Figure 5. Schematic diagram of Tractor Implement System

The motion equations can be expressed as

$$(M_T + M_I)\ddot{z} = f_1 + f_2 - (M_T + M_I)g \quad (3)$$

The displacement of wheels can be calculated as

$$z_1 = z + \left(l_1 + l_3 \frac{M_I}{M_T + M_I} \right) \quad (4)$$

$$z_2 = z + \left(l_2 - l_3 \frac{M_I}{M_T + M_I} \right) \quad (5)$$

The effect of implement on displacement of wheels can be calculated from equations (3) and (4). So the effective mass of tractor and implement will be expressed by m_t and its effect on wheel displacements, roll, yaw and pitch of tractor implement system will be included by using equations (1) to (4). Off-road vehicles like tractors operate without primary suspension. The tires play a role of spring cushion due to the bending of the tire and the properties of the air in the reduction of energy. The conventional suspension system of the tractor is modelled as damping of the tires of the tractor and the driver's/operator seat, which is a type of suspension for the operator of the tractor. Since the front axle of the tractor rotates towards the centre of the tractor chassis, this must be considered when modelling the vibration model of the tractor.

Figure 6 presents the physical model of the complete tractor with implement. This complete model consists of three sub-models: four wheels, a body and a driver's seat.

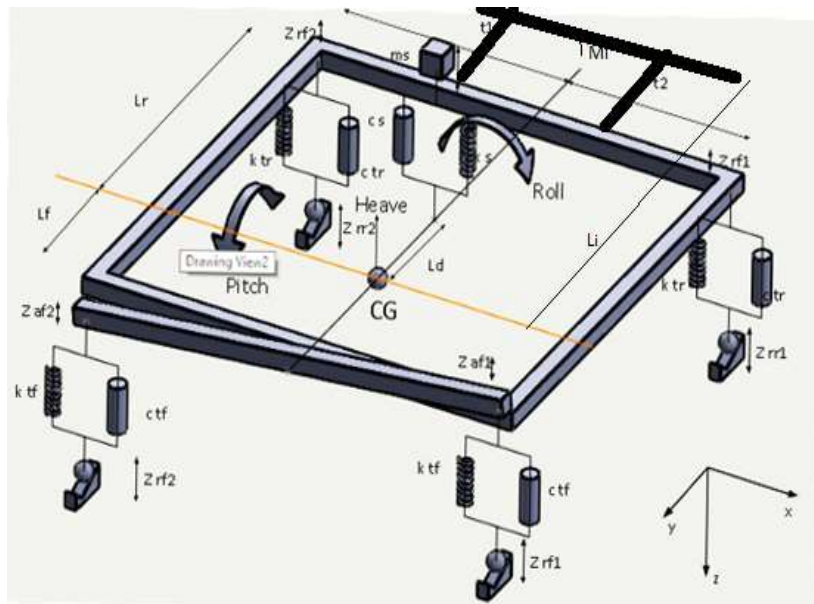

Figure 6. Complete tractor implement vibration model

4.1 Mathematical Full Tractor with Suspended Seat Model

In mathematical modelling, the motion of equations were derived for each of the five degrees of freedom. It is well known fact that the force of spring is proportional to the variation of the length of the spring and that the strength of the shock absorber that is damper force is proportional to variation of the length of damper over time. The vibratory forces transmitted by each wheel at the point of contact between the axle and the wheel can be formulated as follows:

$$k_t(z_a - z_R) + c_t(\dot{z}_a - \dot{z}_R) \quad (6)$$

The mathematical equations for the forces transmitted to chassis are given as:

$$F_{f1} = k_{tf}(z_{af1} - z_{Rf1}) + c_{tf}(\dot{z}_{af1} - \dot{z}_{Rf1}) \quad (6a)$$

$$F_{f2} = k_{tf}(z_{af2} - z_{Rf2}) + c_{tf}(\dot{z}_{af2} - \dot{z}_{Rf2}) \quad (6b)$$

$$F_{r1} = k_{tr}(z_{ar1} - z_{Rr1}) + c_{tr}(\dot{z}_{ar1} - \dot{z}_{Rr1}) \quad (6c)$$

$$F_{r2} = k_{tr}(z_{ar2} - z_{Rr2}) + c_{tr}(\dot{z}_{ar2} - \dot{z}_{Rr2}) \quad (6d)$$

The mathematical equations of the body of tractor are the following:

- (i) for the linear acceleration of the centre of gravity of the tractor in Z direction

$$\ddot{z}_{cg} = -\frac{1}{m_t}(F_f + F_{r1} + F_{r2}) \quad (7)$$

- (ii) for angular accelerations of the tractor body about X-axis which crosses the center of gravity of the tractor

$$\ddot{\theta} = \frac{1}{I_{xxt}}(F_f l_f - (F_{r1} + F_{r2})l_r) \quad (8)$$

- (iii) for angular accelerations of the tractor body about Y axis passing through the center of gravity of the tractor is

$$\ddot{\phi} = \frac{1}{I_{yyt}} (F_{r2}t_2 - F_{r1}t_1) \quad (9)$$

Calculation of bouncing, rolling and pitching motion of tractor body leads to an acceleration of driver's seat base of the tractor. The elements of the base of seat can be computed, provided that the distance between the center of gravity of the tractor and seat base are known. The equation of motion of seat base of tractor is given as (Ahmadi, 2014):

$$\ddot{Z}_{seat\ base} = \ddot{Z}_{cg} \quad (9a)$$

$$\dot{Y}_{seat\ base} = R\dot{\phi} \quad (9b)$$

$$\dot{X}_{seat\ base} = R\dot{\theta} \quad (9c)$$

$\ddot{Z}_{seat\ base}$, $\dot{Y}_{seat\ base}$, $\dot{X}_{seat\ base}$ – acceleration of tractor seat base in z direction, y direction and z direction (m/s²) respectively.

The accelerations of the points of force application to the tractor body (comprising the acceleration of the pivot point of front axle and acceleration of the joints of the tractor rear wheels of the tractor body) may be computed as following (Sarami 2009):

$$\ddot{z}_{afc} = \ddot{z}_{cg} - l_f\ddot{\theta} \quad (10)$$

$$\ddot{z}_{ar1} = \ddot{z}_{cg} - l_r\ddot{\theta} + t_1\ddot{\phi} \quad (11)$$

$$\ddot{z}_{ar2} = \ddot{z}_{cg} - l_r\ddot{\theta} - t_1\ddot{\phi} \quad (12)$$

The accelerations in linear direction of the joints between front axle and front wheels are indicated as follows:

$$\ddot{\alpha} = \frac{1}{I_{xxa}} (F_{f1}t_1 + F_{f2}t_2) \quad (13)$$

Finally, the mathematical equations for the accelerations in linear of the axles of front wheel joints can be computed as follows:

$$\ddot{z}_{af1} = \ddot{z}_{afc} + t_1\ddot{\alpha} \quad (14)$$

$$\ddot{z}_{af2} = \ddot{z}_{afc} + t_2\ddot{\alpha} \quad (15)$$

5. FULL TRACTOR MODELLING USING SIMULINK

Table 1. Parameters of full tractor vibration model

Notations	Description	Values	Units
k_{tf}	stiffness of front tire of tractor	90,000	N/m
c_{tf}	damping of front tire of tractor	1,000	N-s/m
k_{tr}	stiffness of rear tire of tractor	90,000	N/m
c_{tr}	damping of rear tire of tractor	2,000	N-s/m

m_t	Mass of tractor	2,800	Kg
t_1	Distance of center of gravity of tractor from left portion of chassis	0.87	M
t_2	Distance of c.g of tractor from right portion of chassis	0.87	M
l_r	Distance of center c.g. of tractor from rear portion of chassis	0.91	M
l_f	Distance of c.g of tractor from front portion of chassis	1.35	M
I_{xxt}	Mass MOI of tractor about x axis	600	kg-m ²
I_{yyt}	MOI of tractor about y axis	2,000	kg-m ²
I_{xxa}	Mass MOI of tractor front axle about the pivot point	5	kg-m ²
m_s	Mass of seat	35	Kg
l_d	Longitudinal distance of seat from center of gravity	0.69	M
k_s	stiffness of seat	8000	N/m
c_s	Damping of seat	130	N-s/m

Figure 7 shows a developed MATLAB- Simulink computer model of the full tractor model.

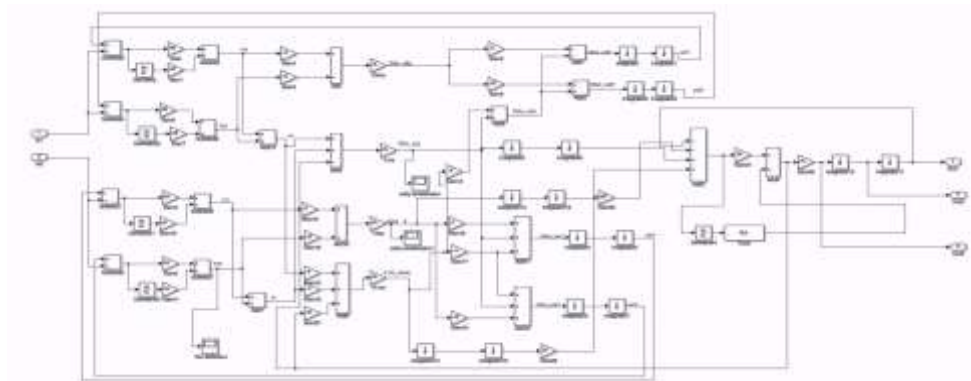

Figure 7. Full Tractor-Implement Simulink Model

The source block or input is the signal generator representing the sine input with 0.01m amplitude and 35 Hz frequency and step function with the height of 1 unit up at 5 sec and 1 unit down at 7 sec for front wheel were selected. The time for step up and down for rear wheel was 8 sec and 10 sec respectively. At time t_0 and t_1 , the road inputs were applied to

the front and rear wheels of modeled tractor, respectively. The time period of t_0 and t_1 is contemplated in relation to the distance between the front and rear axle (Wheel Base), WB, and the speed (v) of the tractor as:

$$t_1 - t_2 = \frac{\text{Wheel Base (WB)}}{\text{Velocity of tractor (v)}} \quad (16)$$

The developed Simulink model of disturbance input for front and rear wheel is presented in Figure 8 (a) and (b), respectively.

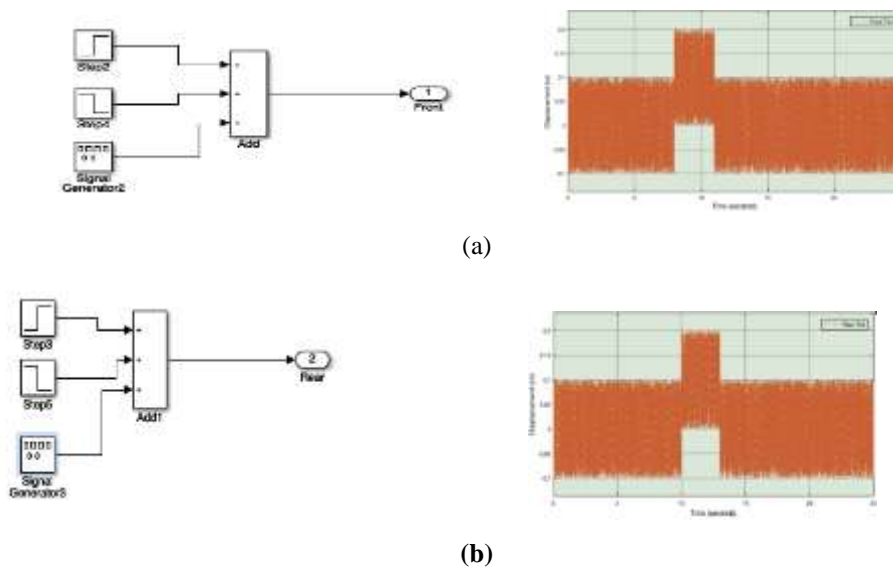

Figure 8. Road Input (a) Front wheels (b) Rear wheels

5.1 Validation of Simulated Dynamic Tractor-Implement Model In the quantitative comparison, a step function was selected as the input displacement functions. In order to simulate the moving tractor at a speed of 3.5 km/h, and a wheel base of 1970 mm (as for test tractor) over a step like hurdle, a time delay of the rear wheels was two second as follows:

$$t = \frac{1970(\text{mm})}{3.5\left(\frac{\text{km}}{\text{hr}}\right)} = \frac{1.97}{0.972(\text{m/s})} = 2.026\text{s} \quad (17)$$

Based on the time domain results, a comparison of the simulation acceleration and the real test acceleration was performed using Root Mean Square (RMS) values.

5.2 Comparison of Simulated and Experimental Results

The modified inputs resulted in RMS errors of 1%, 2.2% and 5.2% respectively in X, Y and Z directions. Hence, the modified model indicated the reliability of the model in simulating the seat base acceleration caused by a tractor moving over step-like random irregularity. To validate the developed vibration model, the results of the modified model obtained in this

investigation were compared with the calculation of the RMS value of acceleration and the estimation of the simulation error used by other researchers. The modified model showed excellent results with the simulation error of 1%, 2.2% and 5.2% which was found to be lower than 10% of the developed models of other studies. The results obtained suggests that the developed computer model could accurately model the induced vibrations by the field irregularity transmitted to the tractor seat. This model can therefore be used to simulate the test required for the design of the controller for seat suspension of tractor

6. RESULTS AND DISCUSSION

The parameter values of tractor were put into MATLAB Simulink model of tractor with implements and RMS values of simulated model was compared with experimental RMS values. Some parameters was redefined to reduce the percentage error in measured and simulated values. The modified inputs resulted in RMS errors of 5.2%, 1% and 2.2% respectively in X, Y and Z directions. Hence, the modified model indicated that model is reliable in simulating the seat acceleration caused by a tractor moving over random irregularity. To validate the developed vibration model, the results of the modified model obtained in this investigation were compared with the calculation of the RMS value of acceleration and the simulation error used by other researchers. The modified model showed excellent results with the simulation error of 5.2%, 1% and 2.2%, which was found to be lower than 10% of the developed models of other studies.

7. CONCLUSION

As the errors in simulated and measured values are less than 10% so this model can work accurately for vibrations of tractor seat during tillage. As the model is comparable with actual tractor –implement system, a number of other studies can be carried out by changing the input parameters like speed and type of tillage implement in simulated model without performing actually on tractor. With use of this model further studies to design a controller to reduce tractor seat vibrations can be designed.

REFERENCES

- [1] Gu, Z.Q., Oyadiji, S. O., “Application of MR damper in structural control using ANFIS method”, *Computers and Structures*, 86, pp. 427–436, 2008.
- [2] Han, Y. M., Jung, J. Y., Choi, S. B., Choi, Y. T., Wereley, N. M., “Ride Quality Investigation of an Electrorheological Seat Suspension to Minimize Human Body Vibrations,” *Proceedings of the Institution of Mechanical Engineers, Part D: Journal of Automobile Engineering*, Volume: 220, pp. 139–150, 2006.
- [3] Han, Y. M., Nam, M. H., Han, S. S., Lee, H. G., Choi, S. B., “Vibration control evaluation of a commercial vehicle featuring MR seat damper”, *Journal of Intelligent Material Systems and Structures*, 13(9), pp. 575-579, 2002.
- [4] Hansen, M. R., & Andersen, T. O., “Active Damping of Oscillations in Off Road Vehicles,” *8th Scandinavian Intl Conference on Fluid Power*, 2, pp. 1073-1085, 2003.
- [5] Hansson, P. A., “Optimization of Agricultural Tractor Cab Suspension Using the Evolution Method,” *Computers and Electronics in Agriculture*, 12, pp. 35-49, 1995.

- [6] Hansson, "Rear axle suspensions with controlled damping on agricultural tractor," *Computers and Electronics in Agriculture*, 15, pp. 123-147, 1996.
- [7] Hansen, M. R., Andersen, T. O., "Active damping of oscillations in off road vehicles," *8th Scandinavian International Conference on Fluid Power*, 2, pp. 1073-1085, 2003.
- [8] Heo, S., Park, K., Hwang, S., "Performance and design consideration for continuously controlled semi-active suspension systems," *International Journal of Vehicle Design*, 23 (3), pp.376-389, 2003.
- [9] He, Y., McPhee, J., "Multidisciplinary design optimization of mechatronic vehicles with active suspensions," *Journal of Sound and Vibration*, 283, pp. 217-241, 2005.
- [10] Hiemenz, G. J., Hu, W., Wereley, N. M., "Semi-active magnetorheological helicopter crew seat suspension for vibration isolation," *Journal of Aircraft*, 45, pp. 945-953, 2008.
- [11] Hilton, D. J., Moran, P., "Experiments in improving tractor operator ride by means of a cab suspension," *Journal for Engineering Research*, 20 (4), pp. 433-448, 1975.
- [12] Ho, D. W., Niu, Y., "Robust fuzzy design for nonlinear uncertain stochastic systems via sliding-mode control," *IEEE Trans Fuzzy System*, 15, pp. 350-358, 2007.

Biographies



Harbhinder Singh is presently working as an Assistant Professor in Mechanical Engineering Department, University Institute of Engineering and Technology, Panjab University Chandigarh. He completed his M.Tech from I.K. Gujral Punjab Technical University in 2005 and B.Tech. from Punjab Technical University in 1998. He is research scholar at School of Mechanical Engineering, Lovely Professional University, Phagwara, Punjab His research interests include design engineering, controls modeling and simulation. He has published various research papers and book chapters in different national/international journals and conferences of repute. He has supervised and guided various dissertations and projects at PG and UG level. He has 20 years of teaching experience to his credit.

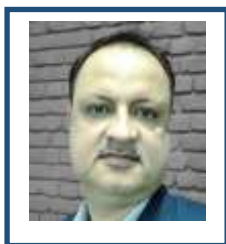

Dr. Munish Mehta is presently working as an Associate Professor in the School of Mechanical Engineering, Lovely Professional University, Phagwara, Punjab. He completed his Ph. D. from I.K. Gujral Punjab Technical University in 2018 and M. Tech. from National Institute of Technical Teachers Training and Research (NITTTR) Chandigarh in 2010. He obtained his B.E. from Nagpur University in 1997. His research interests include reliability engineering, optimization, stochastic modeling, mechatronics and genetic algorithm etc. A lifetime member of ISTE, he has published various research papers and book chapters in different national/international journals and conferences of repute. His academic achievements include serving as reviewer of many reputed journals. He has supervised and guided various dissertations and projects at PG and UG level. He has organized a national conference as organizing secretary. He has 7 years of industrial and 16 years of teaching experience to his credit.